

# Turntables for tube machining

## TVP-160M Welding Positioner

with increased torque, suitable for tube machining

### Useful and multifunctional

The TVP-160M is the best solution for lifting, turning and tilting pipes

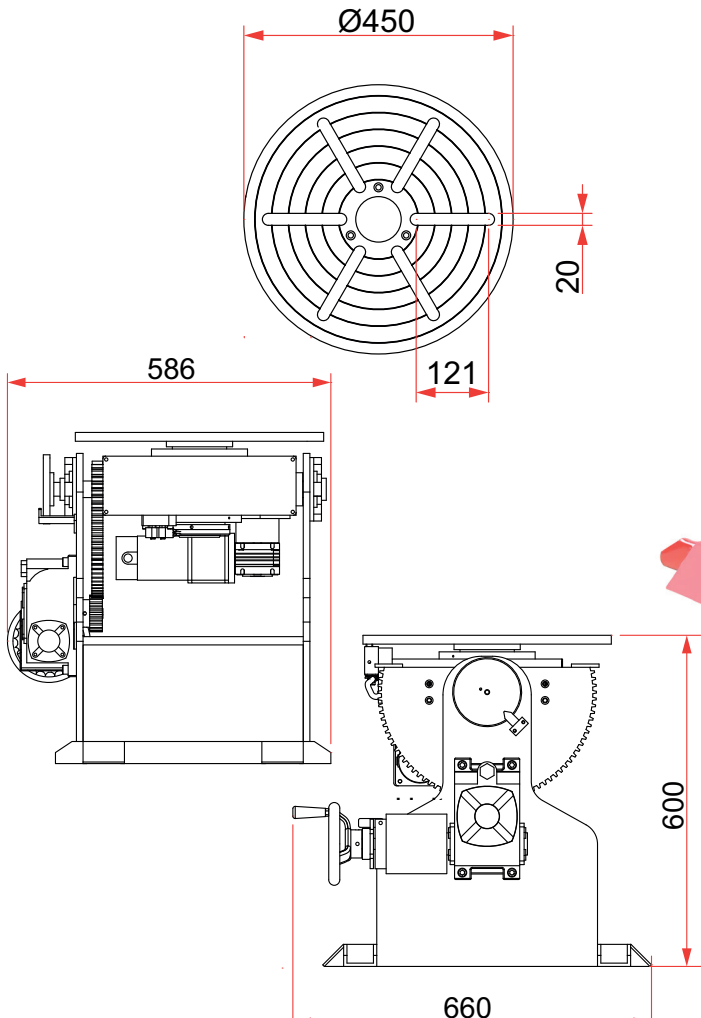
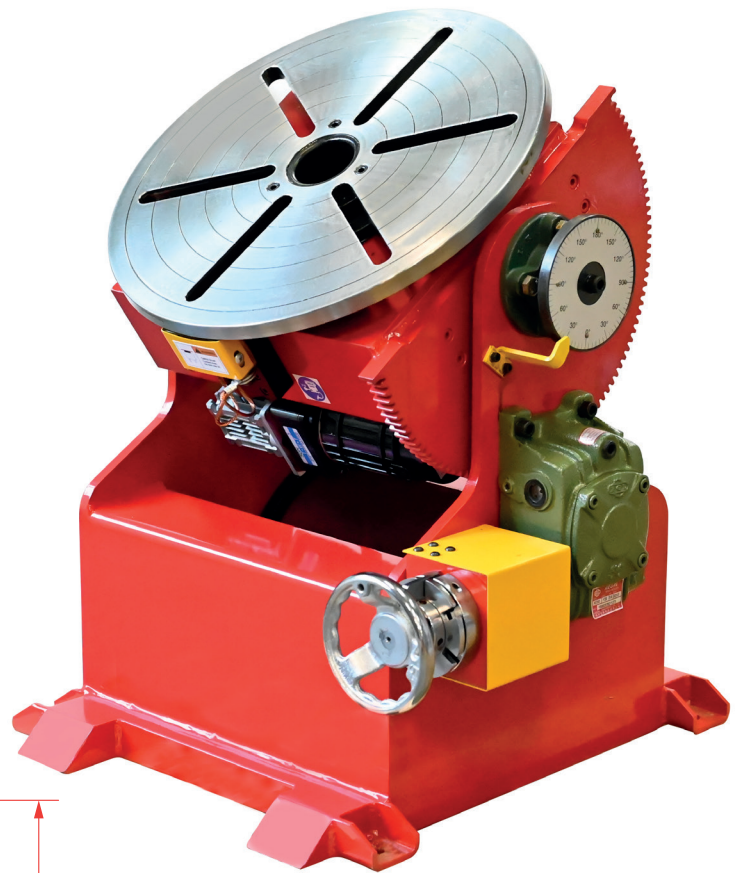

### Eccentric Center (cm)

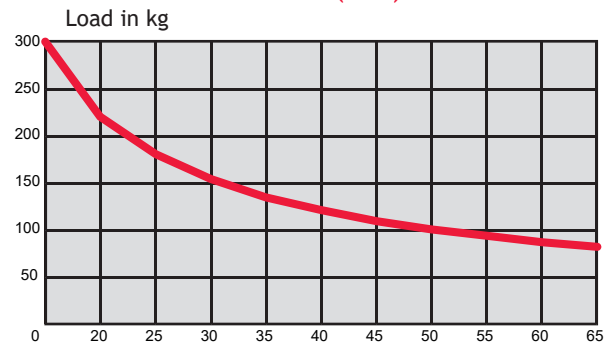

### Center of Gravity (cm)

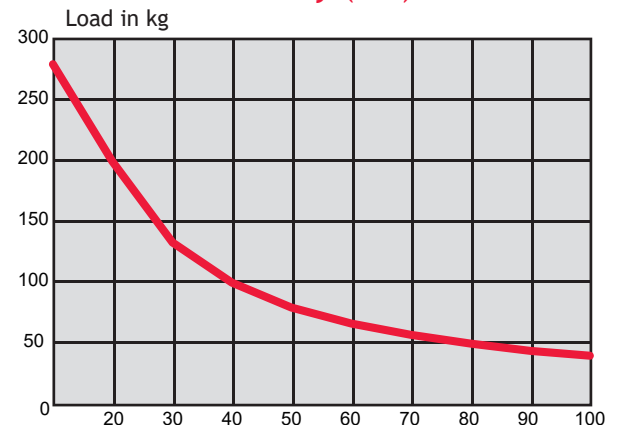

Model	TVP-160 MN
Drive motor	DC65W/90V Motor
Max. load	200 kg
Eccentricity	20 mm
Center of Gravity	100 mm
Table diameter	450 mm
Table Speed	0,6 - 6,0 RPM
Torque	19,6 Nm
Table tilt angle	90° - 270°
Tilt speed	manual
Table angle lock	Screw fixed
Welding current	300 A / 100%
Item no. TVP-160 MN	02.30.01.11160

COM-1000: easy control start/stop, cw/ccw

COM-1802: easy control start/stop, cw/ccw

COM-2802: with overlap welding, pneumatic control for automated welding