

Pipe Processing Unit

Rotator RW1T

Features

- Compact and sturdy design
- For welding, cutting and grinding
- A wide range of pipes can be processed
Even pipe elbows or flanges are no problem
- Clamping without chuck
- lap-welding possible



Model	RW1T
Supply voltage	AC 230 V/50 Hz
Max. Load	2.000 kg
Workpiece diameter	50 - 400 mm
Min. workpiece length	450 mm
Rotation speed	200 - 2.000 mm/min.
Torch stroke, vertical	100 mm
Torch stroke, horizontal	200 mm
Speed control	Inverter
Item no.	02.30.21.00010

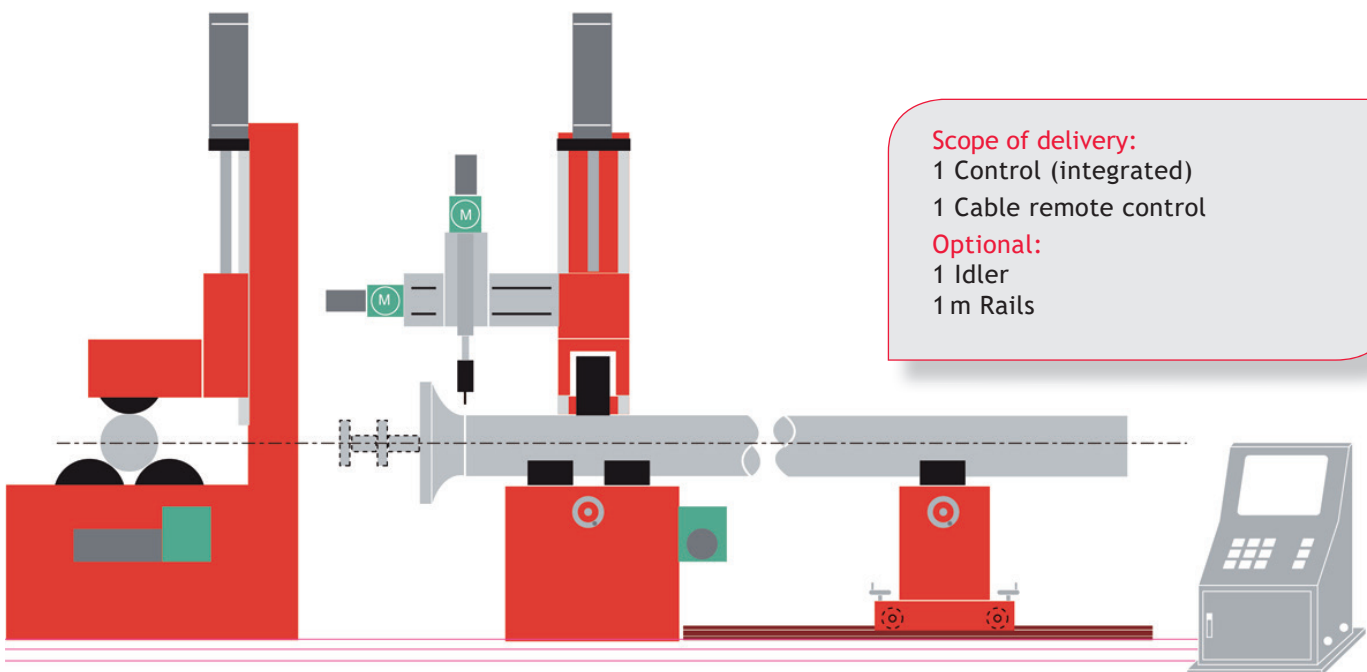

- Scope of delivery:**
1 Control (integrated)
1 Cable remote control
- Optional:**
1 Idler
1 m Rails