

Support Block

support block to 1000 kg load

Support Block RVE 1

Features

- RVE-1 model Pipe Feeding Housing is designed for rolling of pipe workpiece over it.
- RVE-1 model Pipe Feeding housing as standard 1000 kg is presented.
- RVE-1 model, according to customer requests, special productions are manufactured in various diameters & capacities.
- RVE-1 model equipment is predominantly designed as feeding of pipes in horizontal-vertical an angular regions in long distance laying of pipes.
- An indispensable solution in construction sites & working areas.
- Operators can work more effective and efficient.

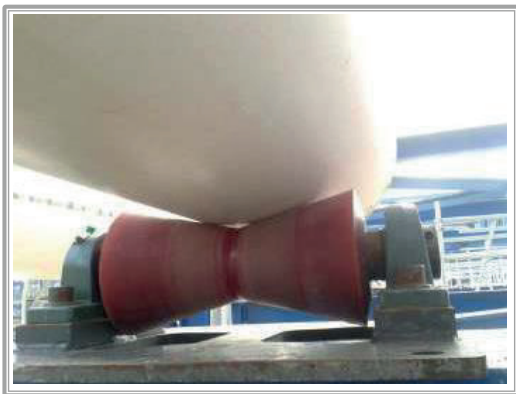

Model	Symb.	RVE-1
Load Capacity		1000 kg
Min.-Max. Rotating Diameter \varnothing		100 - 600 mm
Width	A	400 mm
Length	B	380 mm
Weight		37 kg

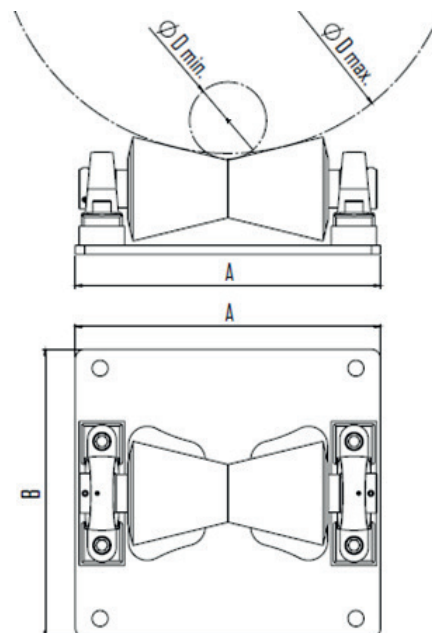

PRICE
ONLY
ON
REQUEST!