

# Welding tractors

## MIG-500 and MIG 502 with magnet

Choice of tractor with battery or mains adapter

### With large scope of delivery

With the MIG 500 and MIG 502 you can easily weld vertically and horizontally, with or without a guide rail. The tractors can be used on different rails.



Model	MIG 500	MIG 502
Supply voltage	DC 24V	DC 24V
Traction power	32 kg	32 kg
Horizontal adjustment	20 mm	20 mm
Vertical adjustment	20 mm	20 mm
Speed mm/min.	35 ~ 930 mm/min.	35 ~ 930 mm/min.
Pivoting movement		0 ~ 65° /min
Dwelling time left/right		0 ~ 2,5 sec.
Oscillation angle		0 ~ ± 5°
Measurements (LxWxH) mm	324 x 300 x 237	320 x 340 x 230
Weight	12 kg	12 kg
Item no.	02.20.01.02010	02.20.01.02020

Accessories optionally for battery mode	Item no.
Charger	02.20.02.11000
Battery MIG 500 and MIG 502	02.20.02.11010
Accessories optionally for mains operation	Item no.
Power supply	02.20.02.11100
Cable set 15 m Control cable 5 m	02.20.02.11105
Accessories optional	Item no.
Adapter for oxyfuel torch	02.20.02.10020

### Scope of delivery:

- 1 Welding tractor
- 1 Pair claws for Nylon- and alu-rail

# Welding tractors

## MIG-500 and MIG 502 with magnet

Choice of tractor with battery or mains adapter

### Features

- Robust, compact casing.
- Easy handling
- Welding in both driving directions possible.
- Continuous driving speed with digital display
- Digital display
- For MIG 502 Oscillator angle
- Also suitable for oxy-acetylene work

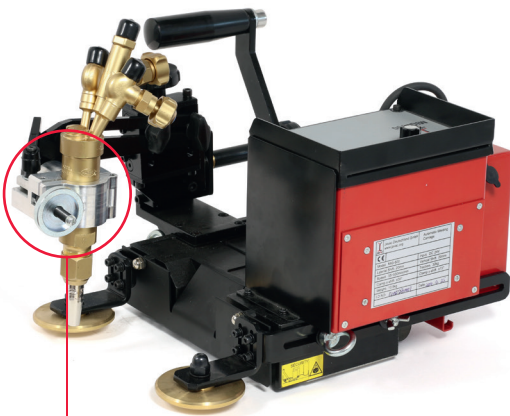
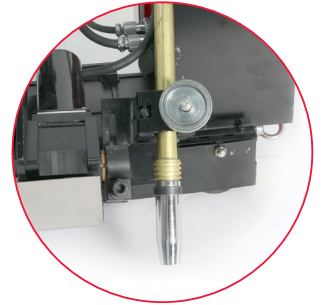

Aluminium guide rail 1,5 m  
Item no. 02.20.02.00080

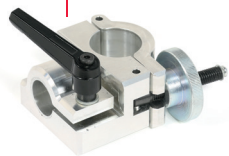
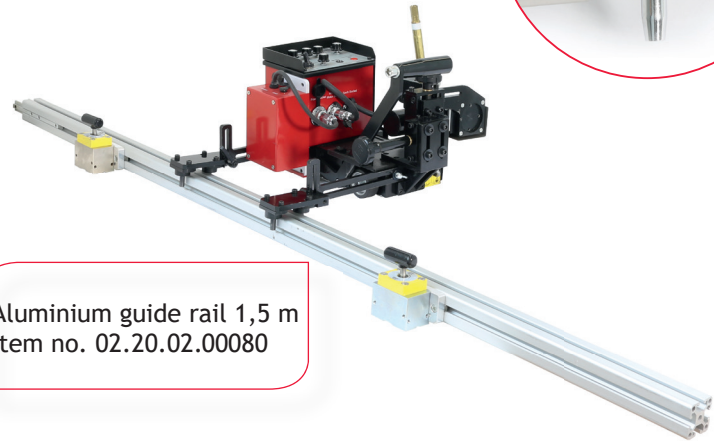

Attachement for cutting torch,  
Item no. 02.20.02.10020



Flexible guide rail 1,5 m  
Item no. 02.20.02.00050



additional battery for MIG 500 and MIG 502  
Item no. 02.20.02.11010



Tractor drive on Flexible steel-rail



User interface of the MIG-500 and MIG-502 welding carriages