

Automation – Girth Welds

Girth Welds Unit LPW

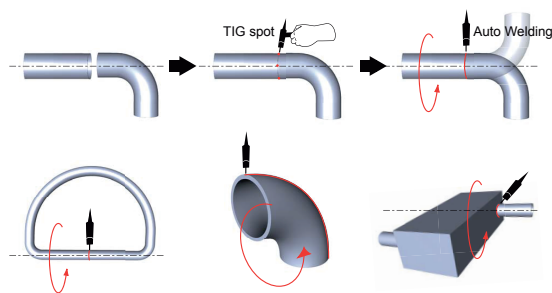
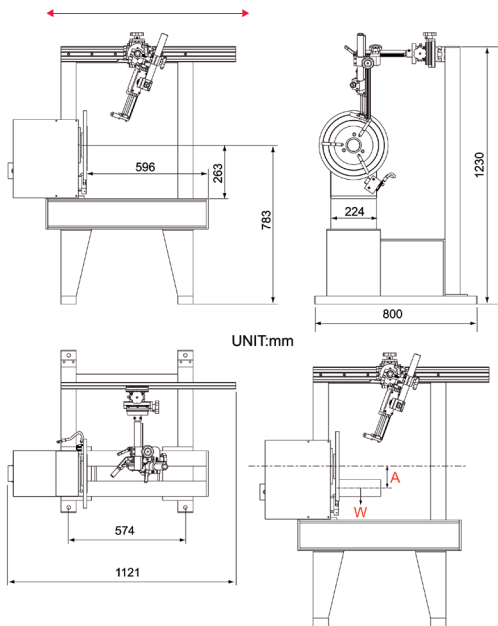

Model	LPW-260	LPW-470
Supply voltage	V1: AC 230 V / 12A / 50;60 Hz V2: AC 400 V / 10A / 50 Hz	V1: AC 230 V / 12A / 60 Hz V2: AC 400 V / 10A / 50 Hz
Permissible welding current	300 A / 100 %	300 A / 100 %
Load	180 kg	250 kg
Table diameter	340 mm	340 mm
Rotating speed	0,6 – 6,0 rpm	0,6 – 6,0 rpm
Max. Workpiece diameter	420 mm	800 mm
Torch X-Lift	75 mm	75 mm
Torch Y-Lift	100 mm	100 mm
Torch Z-Lift	100 mm	100 mm
Overlap timer (fixation point)	0 – 99 sec	0 – 99 sec
Timer (fixation point)	0 – 999 sec	0 – 999 sec
Start / crater filling	0 – 99 sec	0 – 99 sec
operation mode	2-cycle/4-cycle	2-cycle/4-cycle
Bremse	magnetic	magnetic
HF-protection	100 %	100 %
Item no.	02.32.31.00260 (old: 71080707)	02.32.31.00470 (old: 71080714)
Item no. with PLC	02.32.31.00262	

Scope of delivery:

- 1 Control Unit
- 1 Foot switch